



UNIKA D-MOTION



Código	Descripción	Diámetro	Altura	Potencia	Iluminación	Acabado	Embalaje
0810690	Unika D-Motion Slave	75	64	5 W	Natural / Cálida	Ínox	1
0810790	Unika D-Motion TDM	75	64	5 W	Natural / Cálida	Ínox	1
0810890	Unika D-Motion Shucko	75	64	5 W	Natural / Cálida	Ínox	1
0810990	Unika D-Motion USB	75	64	5 W	Natural / Cálida	Ínox	1
0814107	Unika D-Motion Slave	75	64	5 W	Natural / Cálida	Negro Mate	1
0814207	Unika D-Motion TDM	75	64	5 W	Natural / Cálida	Negro Mate	1
0814307	Unika D-Motion Shucko	75	64	5 W	Natural / Cálida	Negro Mate	1
0814407	Unika D-Motion USB	75	64	5 W	Natural / Cálida	Negro Mate	1
0703001	Transformador 15 W-24 Vdc	---	---	15 W	---	Blanco	1
0703101	Transformador 30 W-24 Vdc	---	---	30 W	---	Blanco	1
0707101	Transformador 60 W-24 Vdc	---	---	60 W	---	Blanco	1

i Unika D-Motion Shucko incorpora 1 toma Shucko dotada con cable de 2000 mm. para la conexión directa a la red eléctrica.
 Unika D-Motion USB incorpora 2 tomas de 2 A cada una, dotadas con cable de 2000 mm. para la conexión a un alimentador de 24 Vdc. (Mínimo 30 W).

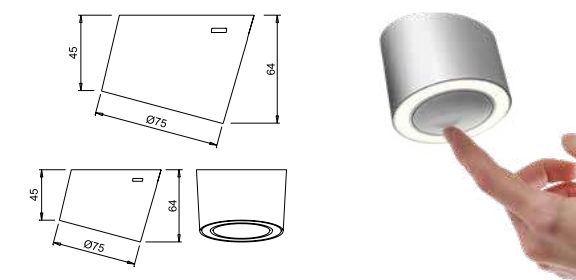
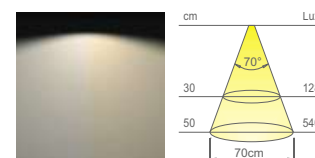



POLAR SE SLAVE



Código	Descripción	Potencia	Acabado	Embalaje
0712787	Polar SE Slave	5 W	Cromo Mate	1
0700707	Polar SE Slave	5 W	Negro Mate	1
0703001	Transformador 15 W-24 Vdc	15 W	Blanco	1
0703101	Transformador 30 W-24 Vdc	30 W	Blanco	1
0707101	Transformador 60 W-24 Vdc	60 W	Blanco	1

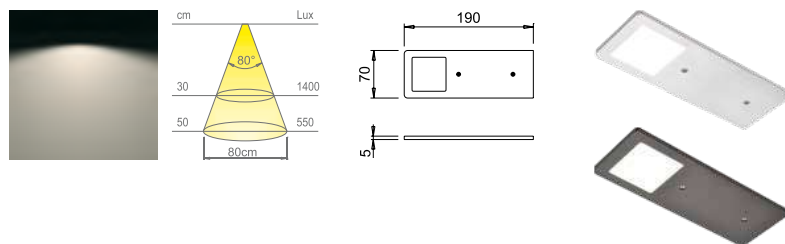

POLAR SE SDM



Código	Descripción	Encendido	Potencia	Acabado	Embalaje
0712887	Polar SE SDM	SDM	5 W	Cromo Mate	1
0700907	Polar SE SDM	SDM	5 W	Negro Mate	1
0703001	Transformador 15 W-24 Vdc	---	15 W	Blanco	1
0703101	Transformador 30 W-24 Vdc	---	30 W	Blanco	1
0707101	Transformador 60 W-24 Vdc	---	60 W	Blanco	1

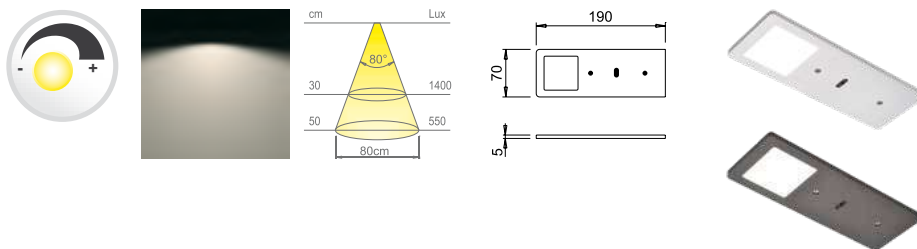

SET 3 K-PAD SDM



Código	Descripción	Encendido	Potencia	Acabado	Embalaje
0712687	Set 3 K-Pad	SDM	15 W	Aluminio	1

El Set incluye; 1 K-Pad SDM + 2 K-Pad Slave + 1 Transformador 15 W

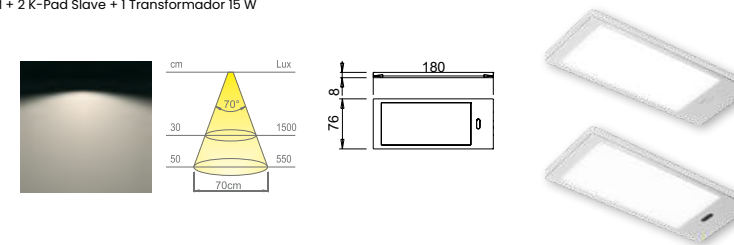

K-PAD IR



Código	Descripción	Encendido	Potencia	Acabado	Embalaje
0712587	K-Pad IR	Infrarrojos	5 W	Aluminio	1
0703001	Transformador 15 W-24 Vdc	---	15 W	Blanco	1
0703101	Transformador 30 W-24 Vdc	---	30 W	Blanco	1
0707101	Transformador 60 W-24 Vdc	---	60 W	Blanco	1

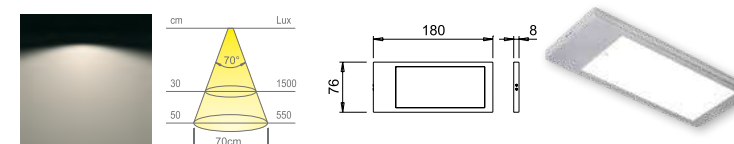



ATOM



Código	Descripción	Ø Encastre	Potencia	Acabado	Embalaje
0712287	Foco Atom	57	3 W	Cromo Mate	1
0700407	Foco Atom	57	3 W	Negro Mate	1
0810190	Foco Atom	57	3 W	Ínox	1
0702287	Spacer Recto Atom	---	---	Cromo Mate	1
0700507	Spacer Recto Atom	---	---	Negro Mate	1
0810290	Spacer Recto Atom	---	---	Ínox	1
0702387	Spacer Oblicuo Atom	---	---	Cromo Mate	1
0700607	Spacer Oblicuo Atom	---	---	Negro Mate	1
0810390	Spacer Oblicuo Atom	---	---	Ínox	1
0703001	Transformador 15 W-24 Vdc	---	15 W	Blanco	1
0703101	Transformador 30 W-24 Vdc	---	30 W	Blanco	1
0707101	Transformador 60 W-24 Vdc	---	60 W	Blanco	1

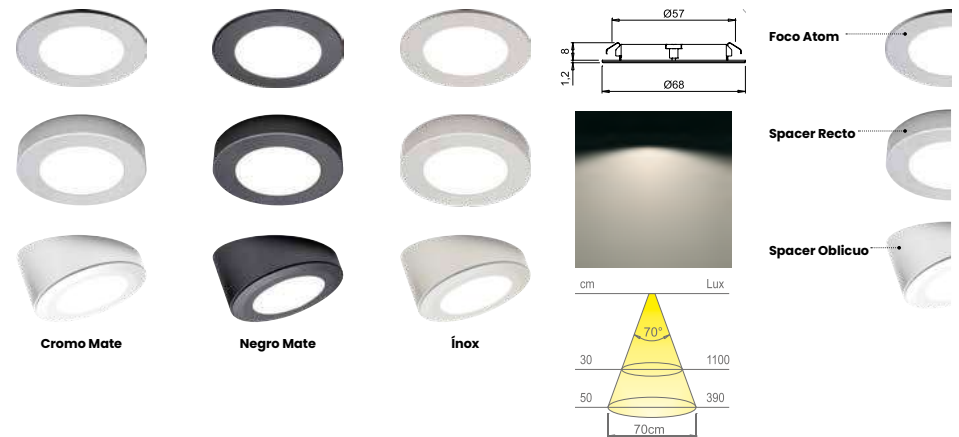



FLEXYLED AT6 (doble cableado)



Código	Descripción	Longitud	Encastre	Potencia	Iluminación	Puntos Led	Embalaje
0810101	Flexyled AT6	2000	6	20 W	Natural	480	1
0810201	Flexyled AT6	3000	6	30 W	Natural	720	1
0810301	Flexyled AT6	2000	6	20 W	Cálida	480	1
0810401	Flexyled AT6	3000	6	30 W	Cálida	720	1
0703001	Transformador 15 W-24 Vdc	---	---	15 W	---	---	1
0703101	Transformador 30 W-24 Vdc	---	---	30 W	---	---	1
0707101	Transformador 60 W-24 Vdc	---	---	60 W	---	---	1

i FLEXYLED AT6 viene de serie con cableado en ambos extremos para un mejor aprovechamiento a la hora de cortar el mismo. Grado de protección IP44. FLEXYLED AT6 está protegido contra salpicaduras de agua. La protección es relativa solo al aparato y no al sistema de conexión.

MODULARIDAD

Doble opción de instalación

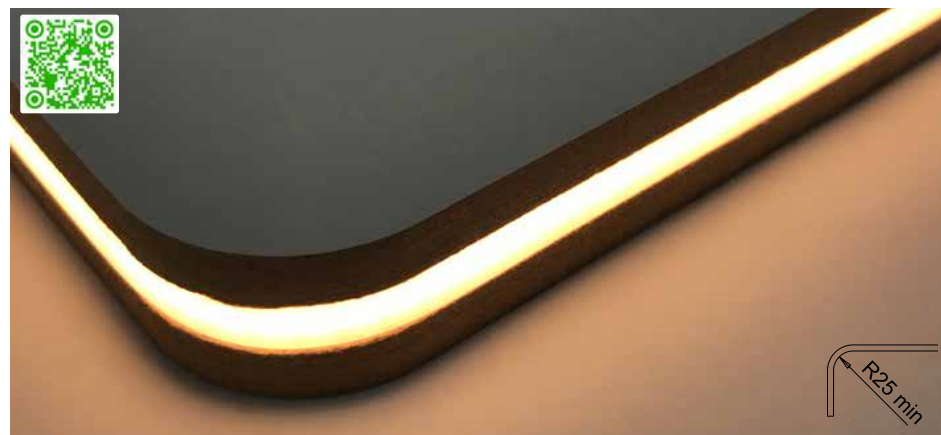
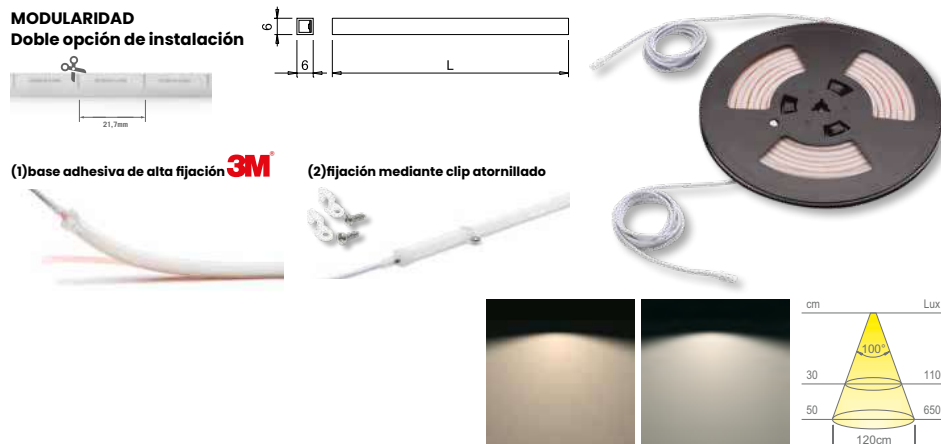

FLEXYLED SE H4 (doble cableado)



Código	Descripción	Longitud	Potencia	Iluminación	Puntos Led	Embalaje
0706501	Flexyled SE H4 Natural Doble Cableado	1000	9,6 W	Natural	180	1
0706601	Flexyled SE H4 Natural Doble Cableado	2000	19,2 W	Natural	360	1
0706701	Flexyled SE H4 Natural Doble Cableado	2500	24 W	Natural	450	1
0706801	Flexyled SE H4 Cálida Doble Cableado	1000	9,6 W	Cálida	180	1
0706901	Flexyled SE H4 Cálida Doble Cableado	2000	19,2 W	Cálida	360	1
0707001	Flexyled SE H4 Cálida Doble Cableado	2500	24 W	Cálida	450	1
0810307	Perfil Tynn Negro Mate	3000	---	---	---	10
0814507	Set 4 tornillos Perfil Tynn	---	---	---	---	20
0703001	Transformador 15 W-24 Vdc	---	15 W	---	---	1
0703101	Transformador 30 W-24 Vdc	---	30 W	---	---	1
0707101	Transformador 60 W-24 Vdc	---	60 W	---	---	1

i FLEXYLED SE H4 viene de serie con cableado en ambos extremos para un mejor aprovechamiento a la hora de cortar el mismo. El Perfil Tynn está pensado para la instalación del Flexyled SE H4 en superficie.

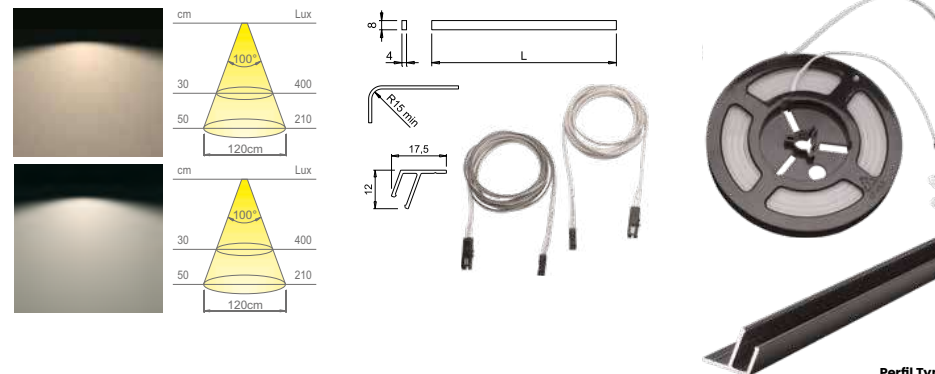



FLEXILED HE CR



Código	Descripción	Potencia	Iluminación	Puntos Leds	Embalaje
0703901	Flexyled HE CR 500 mm.	4,8 W	Natural	60	1
0703601	Flexyled HE CR 1000 mm.	9,6 W	Natural	120	1
0703701	Flexyled HE CR 2000 mm.	19,2 W	Natural	240	1
0703801	Flexyled HE CR 3000 mm.	28,8 W	Natural	360	1
0813601	Flexyled HE CR 500 mm.	4,8 W	Cálida	60	1
0813701	Flexyled HE CR 1000 mm.	9,6 W	Cálida	120	1
0813801	Flexyled HE CR 2000 mm.	19,2 W	Cálida	240	1
0813901	Flexyled HE CR 3000 mm.	28,8 W	Cálida	360	1
0703201	Cable Conexión 2000 mm.	---	---	---	1
0703301	Empalme 500 mm.	---	---	---	1
0703401	Flexyled Corner HE Dcha 60x60	1,1 W	Natural	12	1
0703501	Flexyled Corner HE Izqda 60x60	1,1 W	Natural	12	1
0703001	Transformador 15 W-24 Vdc	15 W	---	---	1
0703101	Transformador 30 W-24 Vdc	30 W	---	---	1
0707101	Transformador 60 W-24 Vdc	60 W	---	---	1

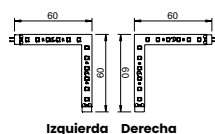
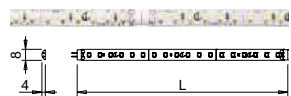
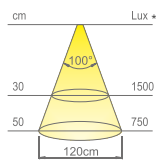
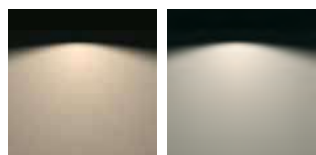

FLEXILED HE CH



Código	Descripción	Longitud	Potencia	Iluminación	Puntos Leds	Embalaje
0811601	Flexyled HE CH 5000 mm.	5000	48 W	Natural	600	1
0811401	Flexyled HE CH 5000 mm.	5000	48 W	Cálida	600	1
0811701	Cable de alimentación Flexyled HE CH	2000	---	---	---	1
0811901	Cable empalme Flexyled HE CH	50	---	---	---	1
0813501	Grapa Flexyled HE CH	---	---	---	---	1
0703001	Transformador 15 W-24 Vdc	---	15 W	---	---	1
0703101	Transformador 30 W-24 Vdc	---	30 W	---	---	1
0707101	Transformador 60 W-24 Vdc	---	60 W	---	---	1

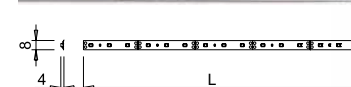
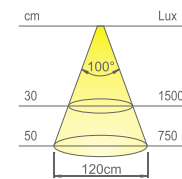
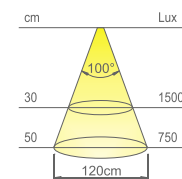
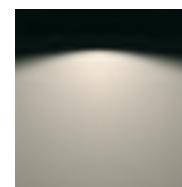

Cable empalme Flexyled HE CH



Grapa Flexyled HE CH

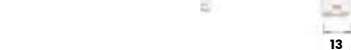

Cable de alimentación Flexyled HE CH





PERFIL DIVA / SENSOR DIVA



Código	Descripción	Longitud	Potencia	Acabado	Embalaje
0702487	Perfil Diva	2000	---	Aluminio	10
0702501	Cobertor Plástico	2000	---	Blanco	10
0702587	Juego Tapas Diva	---	---	Aluminio	20

i Necesario para su instalación la tira Flexyled HE CR.



Perfil Diva / Cobertor Plástico / Jgo. Tapas

PERFIL TWIG / SENSOR TWIG



Código	Descripción	Longitud	Potencia	Acabado	Embalaje
0702687	Perfil Twig	2000	---	Aluminio	10
0702501	Cobertor Plástico	2000	---	Blanco	10
0700193	Clip Fijación Twig	---	---	Cinc	100
0702787	Juego Tapas Twig	---	---	Aluminio	20

i Necesario para su instalación la tira Flexyled HE CR.



PERFIL TWIG XO



Código	Descripción	Longitud	Acabado	Embalaje
0830487	Perfil Twig XO	2000	Aluminio	20
0812001	Cobertor perfil Twig XO	2000	Blanco	10
0800297	Clip de fijación Perfil Twig XO	---	---	20
0820292	Set Tapas Perfil Twig XO	---	Gris	20

i Necesario para su instalación la tira Flexyled HE CH.

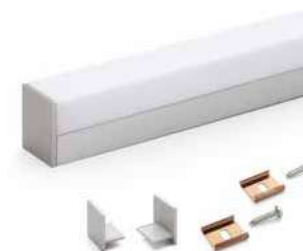
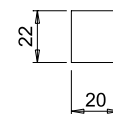

PERFIL THEA



Código	Descripción	Longitud	Acabado	Embalaje
0813907	Perfil Thea	2000	Negro Mate	20
0812101	Cobertor perfil Thea	2000	Blanco	20
0800197	Clip de fijación Thea	---	Cinc	20
0814007	Set de tapas perfil Thea	---	Negro Mate	20

i Necesario para su instalación la tira Flexyled HE CH.

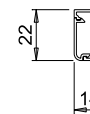



HIDDI NOVEDAD
Lightgroup



Código	Descripción	Encendido	Potencia	Acabado	Embalaje
0814301	Hiddi	Infrarrojos	3,1 W	Blanco	1

i Este artículo, cuenta con un sistema de infrarrojos que se acciona abriendo el frente del cajón o la puerta.





DIAGRAMA DE CONFIGURACIÓN

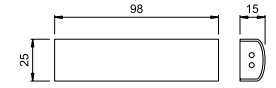
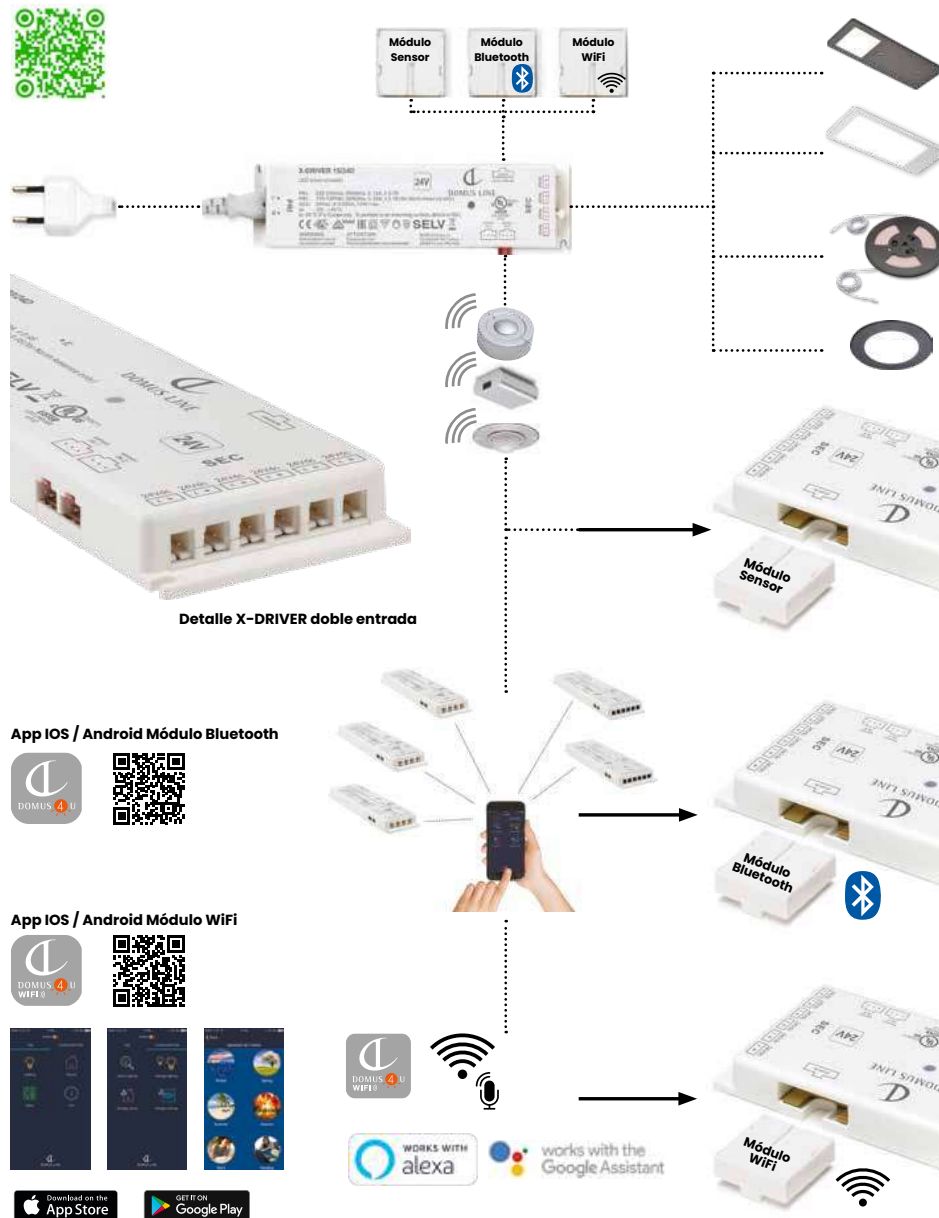

SENSORES INALÁMBRICOS

SENSOR

Gracias a la combinación de X-DRIVER con el módulo sensor, podemos desarrollar una instalación de una forma mucho más sencilla, eliminando todo el cableado que de manera tradicional tiene que ir del transformador al sensor. X-DRIVER, se convierte de esta manera, en un excepcional aliado con el que podemos iluminar nuestros productos de una manera inalámbrica.



DOMUS 4U



BLUETOOTH

DOMUS4U es una aplicación para encender las luminarias conectada a X-DRIVER D-MOTION encendido y apagado y ajuste el brillo y la temperatura de color directamente desde un teléfono inteligente. La señal Bluetooth permite controlar hasta 5 dispositivos X-DRIVER D-MOTION de forma independiente o agrupándolos por habitación. Con DOMUS4U, también puedes elegir, ajustar y asignar configuraciones de iluminación específicas a cada habitación. Necesaria la instalación del módulo Bluetooth.



DOMUS 4U WI-FI



WI-FI

DOMUS4U WIFI es una aplicación para encender las luminarias conectada a X-DRIVER D-MOTION encendido y apagado y ajuste el brillo y la temperatura de color directamente desde un teléfono inteligente. La señal Wi-Fi permite controlar dispositivos X-DRIVER D-MOTION de forma independiente o por agrupación ellos por habitación.



ALEXA & GOOGLE HOME



WI-FI

Fuentes de alimentación X-DRIVER D-MOTION, equipadas con módulo WIFI, se puede interconectar con Amazon y con Google HOME. Dispositivos controlados por voz, con la aplicación Alexa o Google Assistant, es posible encender las luminarias conectando a X-DRIVER D-MOTION encendido y apagado y ajustar el brillo y temperatura de color, utilizando también todos los demás funciones disponibles.





X-DRIVER 15/24D

X-DRIVER 30/24D

X-DRIVER 60/24D

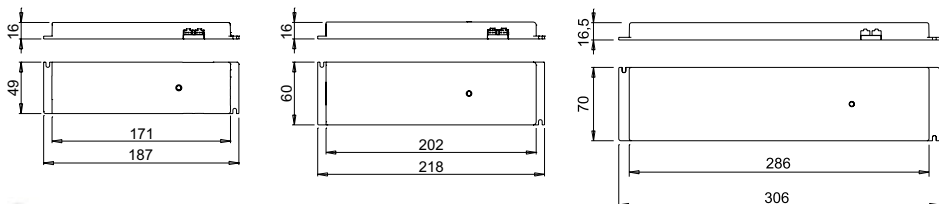

Cable conexión red



Módulo Sensor

Módulo Bluetooth

Módulo WiFi



Call Me W17



IR WI-XD (Proximidad)



PIR WI-XD (Presencia)

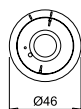
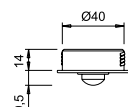
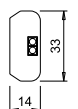
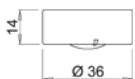

X DRIVER (Transformadores)



Código	Descripción	Longitud	Potencia	Acabado	Embalaje
0810501	X-DRIVER 15/24D	---	15 W	Blanco	1
0810601	X-DRIVER 30/24D	---	30 W	Blanco	1
0810701	X-DRIVER 60/24D	---	60 W	Blanco	1
0810801	Cable conexión red	2000	---	---	1

X DRIVER (Módulos)



Código	Descripción	Acabado	Embalaje
0811001	Módulo Sensor	Blanco	1
0811101	Módulo Bluetooth	Blanco	1
0811201	Módulo WiFi	Blanco	1

Los módulos Bluetooth y WiFi, no podrán combinarse con el transformador X-DRIVER 15/24D. Solo podrán hacerlo con los X-DRIVER 30/24D y X-DRIVER 60/24D

X DRIVER (Sensores inalámbricos)



Código	Descripción	Acabado	Embalaje
0820192	Call Me W17	Aluminio	1
0810607	IR WI-XD (Proximidad)	Aluminio	1
0810407	PIR WI-XD (Presencia)	Aluminio	1



TRANSFORMADOR 15 W-24 Vdc

Código	Descripción	Potencia	Acabado	Embalaje
0703001	Transformador 15 W - 24 Vdc	15 W	Blanco	1

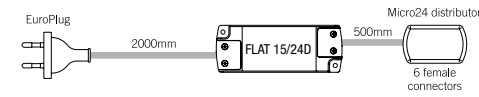
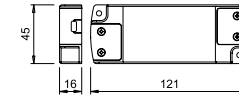

TRANSFORMADOR 30 W-24 Vdc

Código	Descripción	Potencia	Acabado	Embalaje
0703101	Transformador 30 W - 24 Vdc	30 W	Blanco	1

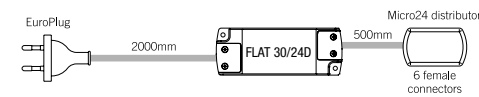
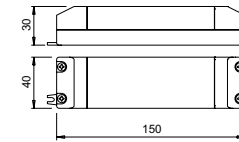

TRANSFORMADOR 60 W-24 Vdc

Código	Descripción	Potencia	Acabado	Embalaje
0707101	Transformador 60 W - 24 Vdc	60 W	Blanco	1

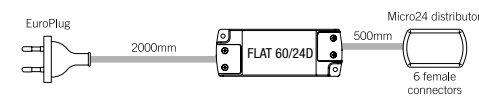
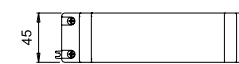



SENSOR IFR V09



Código	Descripción	Potencia	Acabado	Embalaje
0702701	Sensor Infrarrojos IFR V09	150 - 250 w	Blanco	1

i Sensor de presencia. Posibilidad de regular el tiempo de desconexión entre 10 segundos y 3 minutos máximo.

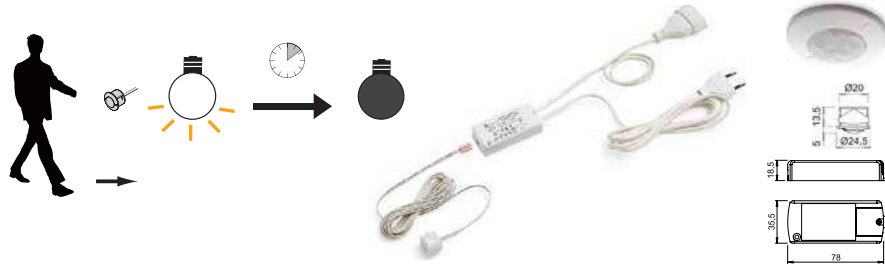

SENSOR SIMPLY



Código	Descripción	Potencia	Acabado	Embalaje
0701207	Sensor Simply R1	150 w	Negro	1

i Sensor de proximidad.



INTERRUPTOR CLICK



Código	Descripción	Acabado	Embalaje
0704201	Interruptor Click	Negro	1



SENSOR OCULTO CAPSENS FW TLD



Código	Descripción	Potencia	Acabado	Embalaje
0702801	Sensor Oculto Capsens	30-60 w	Negro	1

i Sensor touch.

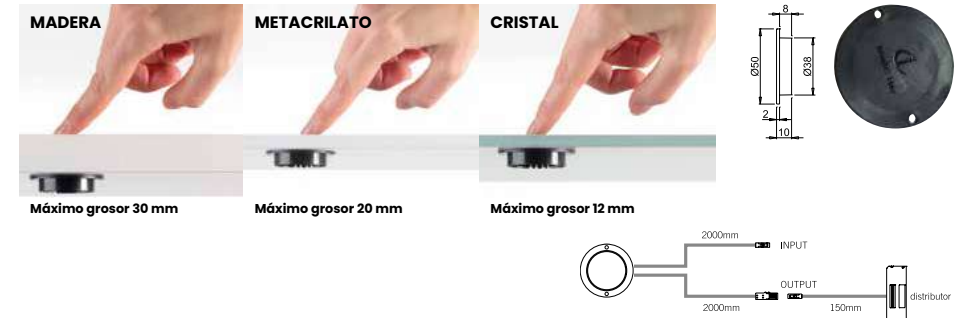

SENSOR IR 12/24 FW



Código	Descripción	Potencia	Acabado	Embalaje
0702601	Sensor Infrarrojos IR 12/24 FW	15 - 30 w	Blanco	1

i Sensor IR 12/24 FW adaptado para una doble configuración. Sensor de puerta o de proximidad.

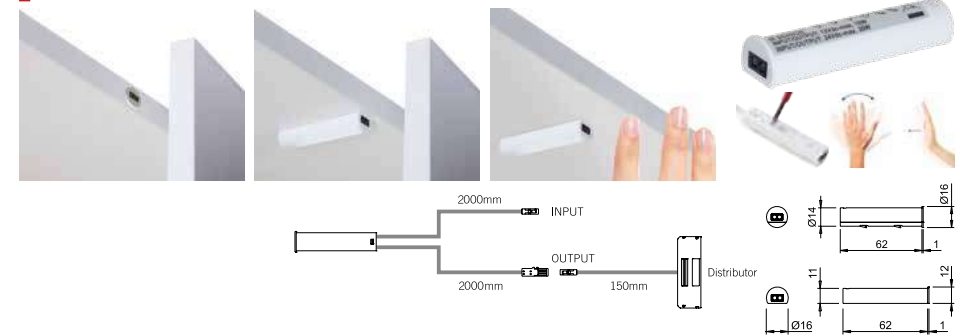

SENSOR DOTTI TLD



Código	Descripción	Potencia	Acabado	Embalaje
0710687	Sensor Touch Dotti	36/72 w	Aluminio	1

i Sensor touch.

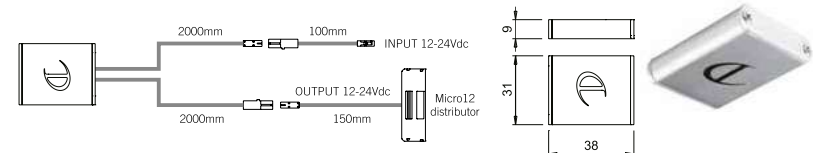



EIGHT

NOVEDAD
Udabgroup



Código	Descripción	Alto	Acabado	Embalaje
0811090	Eight 2 Schuko	457	Ínox	1
0814001	Eight 2 Schuko	457	Blanco Mate	1
0814607	Eight 2 Schuko	457	Negro Mate	1
0811190	Eight 1 Schuko / 1 USB	457	Ínox	1
0814101	Eight 1 Schuko / 1 USB	457	Blanco Mate	1
0814707	Eight 1 Schuko / 1 USB	457	Negro Mate	1

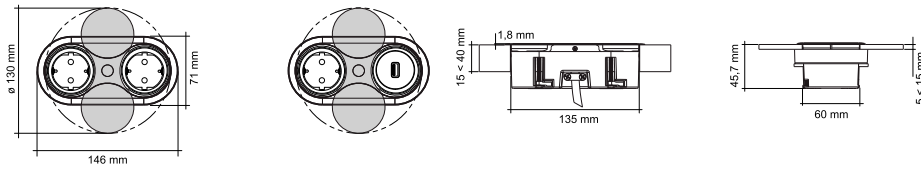

2 SCHUKO

1 SCHUKO / 1 USB CARGADOR 3,5 A



TWIST

Código	Descripción	Alto	∅ Diámetro	∅ Encastre	Acabado	Embalaje
0700690	Twist 2 Schuko	43	115	105	Ínox	1
0706401	Twist 2 Schuko	43	115	105	Blanco Mate	1
0701307	Twist 2 Schuko	43	115	105	Negro Mate	1
0810490	Twist 1 Schuko / 2 USB	43	115	105	Ínox	1
0811301	Twist 1 Schuko / 2 USB	43	115	105	Blanco Mate	1
0810707	Twist 1 Schuko / 2 USB	43	115	105	Negro Mate	1

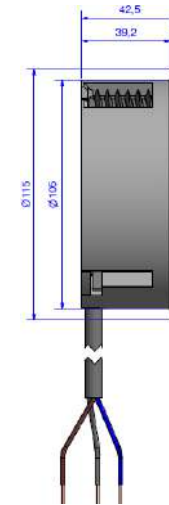

2 SCHUKO

1 SCHUKO / 2 USB CARGADORES 3,5 A



Posibilidad de personalizar los enchufes con logotipo del cliente. Consultar condiciones con Dpto. Comercial.



RING NOVEDAD



Código	Descripción	Alto	Ø Diámetro	Ø Encastre	Acabado	Embalaje
0814201	Ring 1 Schuko / 1 USB	685	85	70/74	Blanco Mate	1
0814807	Ring 1 Schuko / 1 USB	685	85	70/74	Negro Mate	1
0811290	Ring 1 Schuko / 1 USB	685	85	70/74	Ínox	1

i Su válvula está equipada con un sistema de asistencia para la apertura y el cierre, que permite posicionar el bloque tomado tanto en horizontal como en vertical. Ring encaja en una encimera de 5 a 45 mm de espesor y de todos los materiales porque se fija atornillando un anillo.

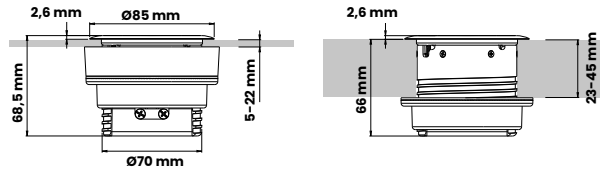

AUTOMATIK NOVEDAD



Código	Descripción	Alto	Ø Encastre	Acabado	Embalaje
0815007	Automatik 2 Schuko / 2 USB	349	85	Negro	1

i Su apertura y cierre son motorizados y asegurados mediante un sistema antipinzamiento, lo que permite su instalación en lugares de difícil acceso. Este producto es IP44 en la posición cerrada. Automatik también ha sido galardonado con un Trofeo en la categoría Equipos-Accesorios en SADECC 2019, así como con un primer premio en el concurso internacional MDO MonteCarlo Prize 2019.



BRICK NOVEDAD



Código	Descripción	Alto	Ø Diámetro	Ø Encastre	Acabado	Embalaje
0811390	Brick 3 Schuko / 2 USB	265	95	80	Ínox	1

i Para evitar cualquier rastro de fricción, el sistema de deslizamiento se realiza sobre 2 rieles laterales y 1 riel trasero. Para instalar en una encimera de 50 mm de espesor máximo.

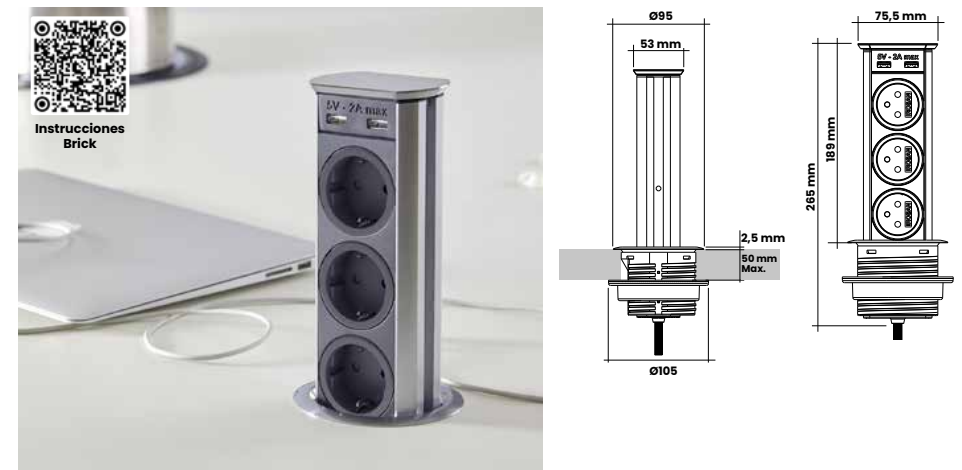



ELEVATOR / COVER

Código	Descripción	Alto	Ø Diámetro	Ø Encastre	Acabado	Embalaje
0700589	Elevator 2 Schuko	135	115	80	Ínox	1
0810590	Elevator 1 Schuko / 2 USB	135	115	80	Ínox	1
0710691	Elevator cover interior	150	127	127	Ínox	1

i Elevator cover interior es simplemente un cobertor decorativo. Hay que pedir siempre el modelo Elevator de forma independiente.

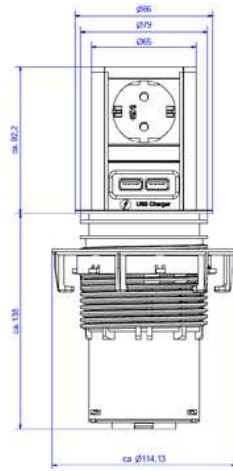

VOLTA



Código	Descripción	Alto	Ø Diámetro	Ø Encastre	Acabado	Embalaje
0711387	Volta 3 Schuko/2 USB	323	72	60	Aluminio	1

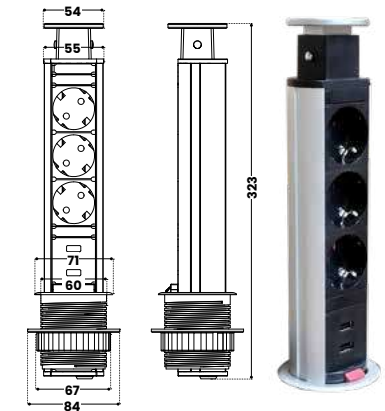

PORT

Código	Descripción	Alto	Ø Diámetro	Ø Encastre	Acabado	Embalaje
0700287	Port 3 Schuko	287	110	102	Aluminio	1

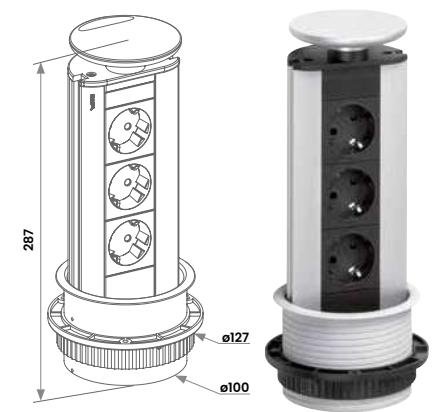



BORN

NOVEDAD
Lidagroup



Código	Descripción	Alto	Ancho	Fondo	Acabado	Embalaje
0814907	Born 1 Schuko / 2 Sockets / 2 USB	42	100	170	Negro Mate	1

i Born es un bloque de enchufes multiposición que ofrece 5 enchufes (1 enchufe schuko de 16 A, 2 enchufes de 6 A y 2 USB 5 V 2 A). De dimensiones muy compactas, puede instalarse debajo de un mueble alto, debajo de una estantería o dentro de un mueble.

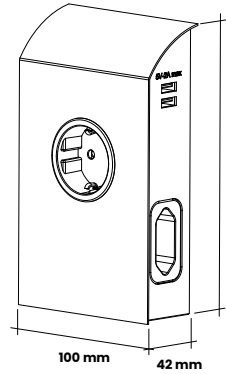

V-DOCK

Código	Descripción	Alto	Ancho	Fondo	Acabado	Embalaje
0700187	V - Dock 3 Schuko	66	211	66	Aluminio / Negro	1

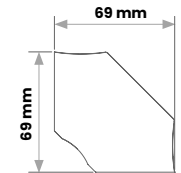

CASIA



Código	Descripción	Alto	Acabado	Embalaje
0710887	Casia 4 Schucko	457 - 585	Aluminio / Negro	1

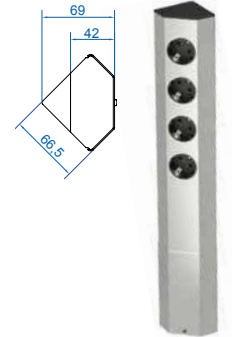



BACK FLIP

Código	Descripción	Alto	Ancho	Fondo	Encastre	Acabado	Embalaje
0701089	Back Flip 2 Schuko 2 USB Cargador	553	226	105,5	215 x 88	Ínox	1

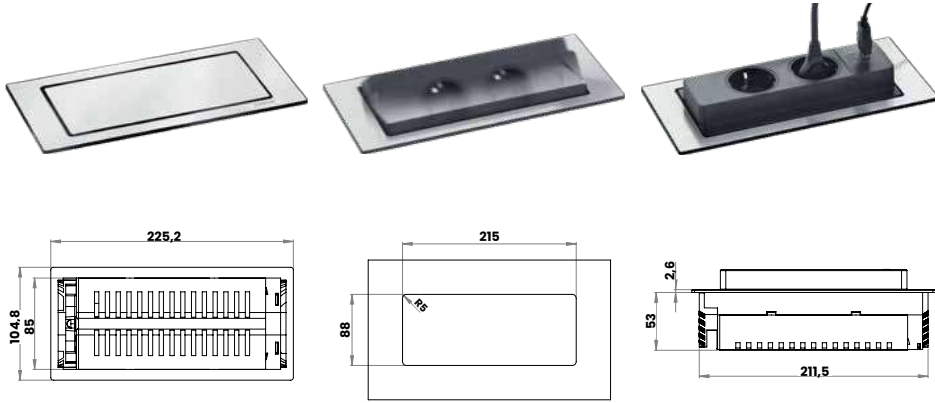

POWER FRAME

Código	Descripción	Alto	Ancho	Fondo	Encastre	Acabado	Embalaje
0703787	Power Frame 2 Schuko 2 USB Cargador	45	256	87	225 x 60	Aluminio	1

